

DC DRIVE - ECO

TECHNICAL DATA

The cooling capacity curves are based on the temperature of oil entering the cooler and the prevailing air temperature. An oil temperature of +60°C and an air temperature of +20° gives a temperature difference of +40°C. Multiply by kW/°C for the total cooling capacity.

Heat dissipation - ECO 015-07

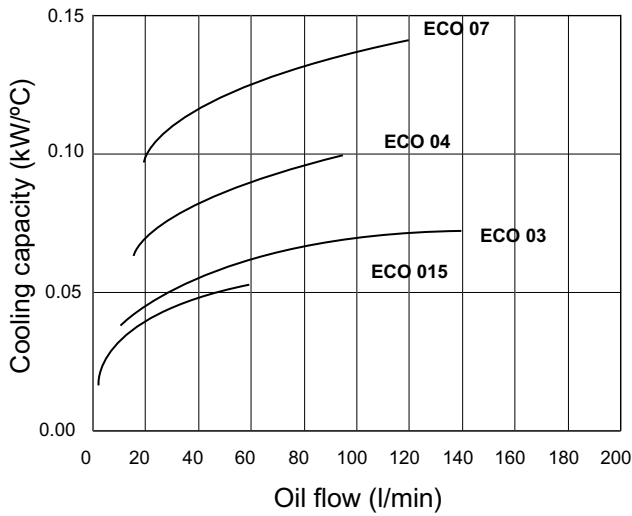

Oil pressure drop - ECO 015-07

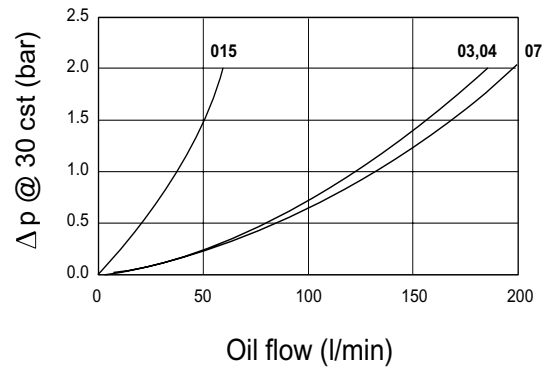

ECO	Noise level	Protection	Air flow (m³/s)	Current draw		Req. fuse		Weight approx. (kg)
				12V (Amp)	24V (Amp)	12V (Amp)	24V (Amp)	
015	70	IP 65	0.12	5A	3A	10A	5A	3
03	70	IP 65	0.15	6A	3A	10A	5A	3.5
04	70	IP 64	0.2	10A	6A	15A	10A	5.5
07	70	IP 64	0.33	20A	11A	25A	15A	8



25

ECO - DC DRIVE

TECHNICAL DATA

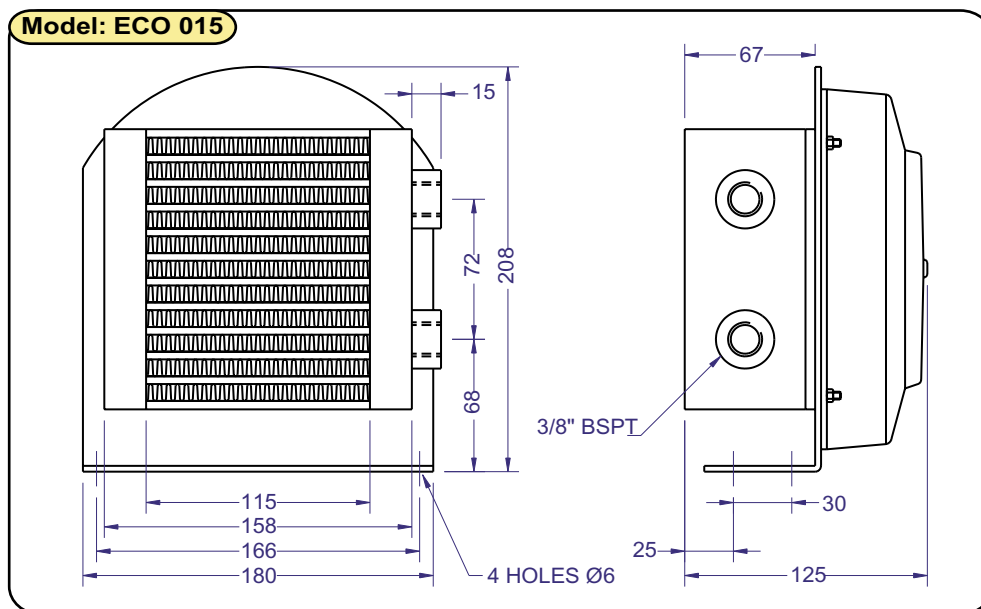

ECO	A	B	C	D	E	F	G	H	I
03	244	174	130.6	-	172	197.6	210	114	Ø210
04	267	197	152.4	-	198	228.6	241	156	Ø247
07	330	260	203	160	262	296	322	159	Ø331

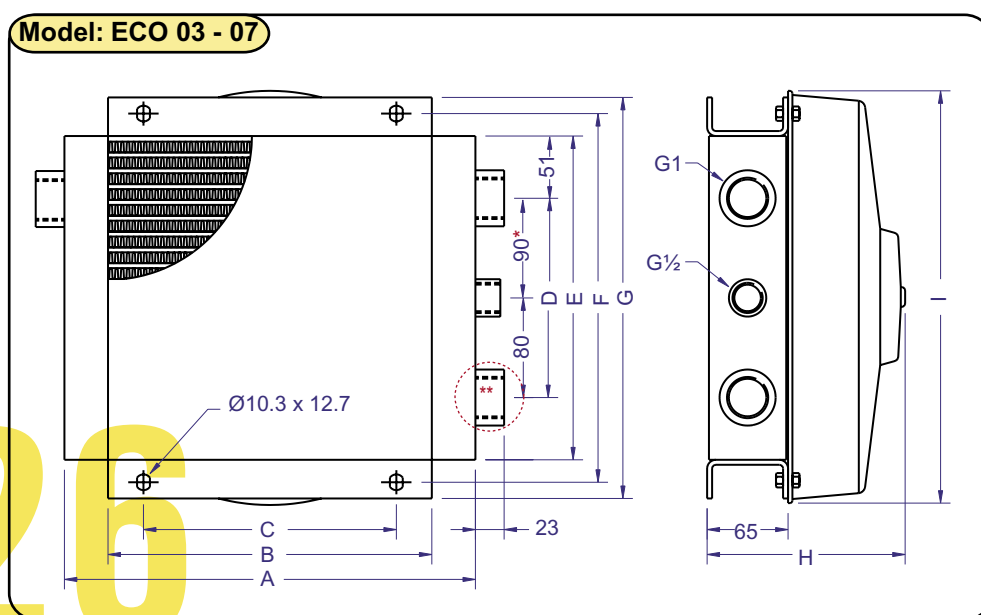

* 03, 04 only

** Not available in 03, 04

26



Distributor

Oil Solutions



Phone 0421 336 009

Fax 03 9012 4332

International

Phone 61 421 336 009

Fax 61 3 9012 4332

sales@oilsolutions.com.au

www.oilsolutions.com.au

PO Box 653 Castlemaine Australia 3450

